

V1.0			

1:1

10:1

1:1

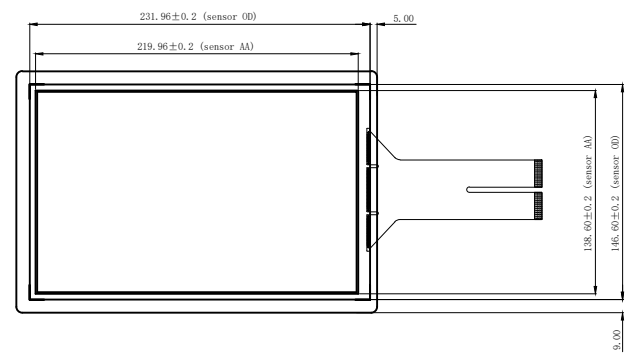
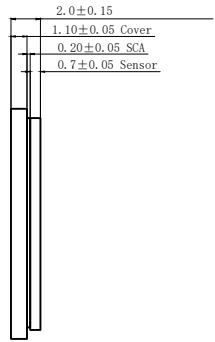
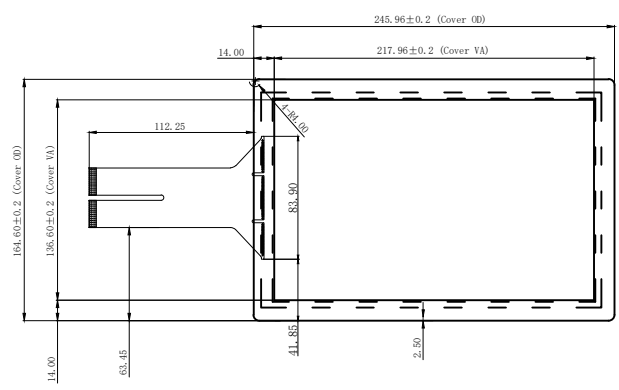

- 1. Cover GLASS+ITO GLASS+SCA+FPC
 Cover GLASS: 1.1mm
 ITO GLASS: 0.7mm
 SCA: 0.2mm
 2.0±0.15mm
- SENSOR: ITO
- 2. 5V/3.3 V
- 3. ≥85%
- 4. 7H
- 5. -20°C~+60°C, ≤90%RH
- 6. -30°C~+70°C, ≤90%RH
- 7. ±0.2mm
- 8. USB
- 9. IC:8752

USB	
PIN	Definition
1	VCC
2	D-
3	D+
4	GND

10.1"		
DRAWN BY:	PRODUCT MODEL: PCAP1010-KR	VIEW:
CHECKED BY:	CUSTOMER ID:	
APPROVED BY:	DATE: 2018-12-04	UNITS mm
Standard tolerance:	WEBSITE:	SCALE 1:1